

Winch and Hoist Solutions

Fulcrum Winches



www.WinchandHoistSolutions.com

IR Ingersoll-Rand.

Fulcrum Winch Series

5300 to 45600 lb (2409 to 20727 kg) capacity



Around 450 B.C. the Greek mathematician Archimedes declared, “Give me a fulcrum on which to rest, and I will move the earth.” Archimedes had created the fulcrum as a tool, a way to gain leverage, and to make it easier for people to accomplish a task. The goal of the new FULCRUM Winch Series is to accomplish the same thing—provide the simplest, most cost-effective and efficient solution to your application.

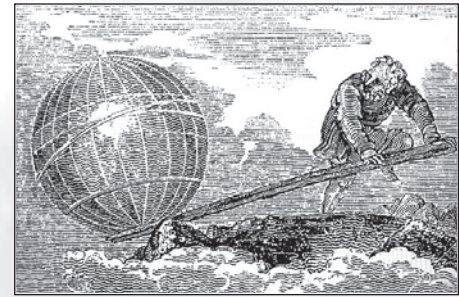

We surveyed a variety of professionals actively operating, installing, and inspecting winches as to which features they’d like to see as part of a new winch line. This diverse group of riggers, end users, and regulatory officials responded back with their requirements: **Safety, Versatility, Reliability, Simplicity, and Availability—all at a reasonable price!**

Ingersoll-Rand has taken on the challenge with over 80 years of electric winch manufacturing experience, creating a tool (much like Archimedes) to make your work simpler and easier...The Fulcrum winch series.

The Fulcrum Leverage...

■ Safety

Instill security and confidence with winches that are built to meet or exceed American National Standard Institute/American Society of Mechanical Engineers (ANSI/ASME) specification B30.7 featuring two dedicated models:

- EL Series for lifting applications with an 18:1 *D/d* ratio
- EP Series for pulling applications with a 15:1 *D/d* ratio
- Plus a **5:1 Design Factor** on every Fulcrum model

■ Versatility

With a wide variety of options the Fulcrum allows you to “customize” a winch to meet your specific needs including:

- 5300 lbs. to 45600 lbs. capacity range
- 69 standard line pull / line speed configurations
- All world wide voltages
- Variable mounting configurations (inverted, side, etc.)
- Underwound or overwound cable take-offs
- 30+ standard options
- Air, Hydraulic and Man Rider™ models available on request
- Engineering support and design modifications available

■ Reliability

Reduce down time and maintenance costs with motors rated for continuous duty operation and gearboxes that are fully sealed to exclude harmful contaminants. The Fulcrum’s planetary type gear reducer is 95% efficient, thereby decreasing the harmful friction and heat build-up so common in helical and worm style gearboxes. These same gear reducers have proven their durability with years of usage in the harsh environment of the offshore oil industry. We’re so confident in the Fulcrum’s design it comes with a **full two-year warranty**, one of the longest available in the industry today!

■ Simplicity of design

- A completely enclosed gearbox and fan-cooled motor, with a self-adjusting brake coupled directly to the drum, provide a straightforward rugged assembly which is simple to operate and maintain.

■ Simplicity of product offering

- Our survey concluded that confusion between different ratings, different design factors, and radically different pricing is common when comparing various manufacturer’s winches. Simply put, the Fulcrum utility winch is available in two versions.

Fulcrum Model	Line pull rated at layer	Winch design factor	<i>D/d</i> ratio	Built to meet or exceed
Pulling (EP)	1st	5:1	15:1	ANSI/ASME B30.7
Lifting (EL)	1st	5:1	18:1	ANSI/ASME B30.7

(1) based on the recommended wire rope for each winch

■ Availability

With locally stocked components, state of the art manufacturing systems, and a winch designed for easy assembly we’ve drastically reduced the long lead-time factors from our delivery equation. The Fulcrum winch series is ready to meet the customer’s “need it now” expectations. Tell us where you want it, when it has to be there, and let us do the rest...

■ Pricing

Dollar for dollar the Fulcrum series is priced to provide value not only at the time of purchase, but over the entire lifetime of the winch. It is built to the highest industry standards with quality components, and a 5:1 design factor, resulting in a winch that continues to provide savings through reduced operating and maintenance costs year after year.

Fulcrum Winch Series

5300 to 45600 lb (2409 to 20727 kg) capacity



The Fulcrum Leverage...

Integral Lifting Eyes

Preformed lifting points are provided on all units to facilitate transport and installation of the winch.



Optional Free-Spooling Drum Clutch

Totally enclosed to eliminate pinch points, the oil bath lubricated, clutch module allows the drum to free-spool. Unique design applies slight resistance on drum to prevent over-running and birdnesting of the cable.

Planetary Gear Boxes

Fully sealed to exclude harmful contaminants. The Fulcrum's planetary type gear reducer is 95% efficient and features constant oil bath lubrication.



Right Angle Drive Gear Reducer

Provides a multitude of mounting configurations by "clocking" the reducer around its mounting flange. The winch can be deck, wall, or ceiling (inverted) mounted.



Regreasable Roller Bearings

All external bearings have readily accessible grease zerks for ease of maintenance.



Cable Anchor

Versatile design accepts multiple wire rope sizes and allows the cable to be spooled from the bottom (underwound) or top (overwound) of the drum.



Manual Brake Release Handle

for lowering of loads in the event of power loss

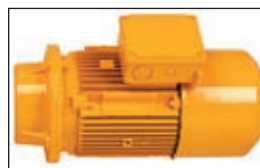

Standard High Torque Continuous Duty Motors

Totally enclosed, fan cooled (TEFC) motors are squirrel cage design, with heavy duty insulation for extended operations in high cycle applications. Available in all worldwide 3 phase voltages.



Drum Diameter Designed to Meet ANSI/ASME B30.7

Large drum diameter enhances spooling and reduces wear on wire rope. 15:1 D/d ratio (EP) pulling models, 18:1 D/d ratio on (EL) lifting models. (D/d = Diameter of the wire rope compared to diameter of drum expressed as a ratio. Lower the ratio the more a rope is forced to bend to wrap around the drum).

Fulcrum FAQs

Q: What is the basis of the Fulcrum design?

A: The Fulcrum is a modular design which allows it to be easily modified to provide the most efficient solution for a given application. A planetary gearbox with a wide range of ratios coupled with a universal motor adaptor allows us to mix and match components to provide line pulls and speeds to meet a client's requirements. From feet per minute to inches per hour, the Fulcrum is able to provide the solutions you require.

Q: What specification is the Fulcrum designed to?

A: Each Fulcrum is designed to meet or exceed ANSI/ASME B30.7 BASE MOUNTED DRUM HOISTS. Since B30.7 does not specifically address what a unit's design factor should be, and because these units could be used for lifting, Ingersoll-Rand has opted for a higher design factor of 5:1 on all models to maximize safety and reliability. This ratio is derived from ANSI/ASME B30.16 OVERHEAD HOISTS (UNDER-HUNG) which requires a 5:1 (minimum) design factor for all load bearing components used in a hoisting application.

Q: Why is there one winch for lifting and one for pulling?

A: Two reasons: First, the Fulcrum is built to ANSI/ASME B30.7 which recommends a minimum winch Drum diameter to wire rope diameter ratio (D/d ratio) of 18:1 for lifting and 15:1 for pulling. This requirement drives the need for two different winch models. Second, the drum diameter affects the amount of torque a winch can provide, so as the diameter increases the line pull decreases slightly (due to "torque arm effect") which results in different rating by model.

Q: What is this D/d ratio?

A: The relationship between the wire rope diameter as it's bent around the Drum's diameter is expressed as a (D/d) ratio. The smaller the ratio the sharper the bend a wire rope must make as it spools onto a drum. Imagine how a garden hose (small "d") would bend and kink if you wrapped it around the small diameter of a pencil (big "D").



Q: Why is the D/d ratio so important?

A: Using a smaller than recommended D/d ratio aggravates the bending motion thereby causing fatigue, irregular wear and accelerated deterioration of wire rope. Increased wear usually results in more frequent inspections and/or wire rope replacement so as to avoid unexpected failures. For this reason Ingersoll-Rand (and most wire rope manufacturers) conform to ANSI/ASME B30.7 which recommends a minimum of 15:1 (D/d) ratio for pulling and hauling applications and a minimum of 18:1 (D/d) ratio for lifting and lowering applications.

To calculate the D/d ratio: Add the drum barrel diameter to the diameter of the wire rope you want to use. Then divide the result by the diameter of the wire rope.

Example: When using .5" wire rope on a 10.75" drum barrel.

$10.75" + .5" = 11.25"$. 11.25 divided by $.5 = 22.5:1$ D/d ratio. This meets both the 15:1 minimum for pulling and the 18:1 for lifting applications.

Q: Why would anyone build a winch that doesn't have the correct D/d ratio or meets ANSI/ASME recommendations?

A: With all inputs being equal, the smaller the drum diameter the greater the load a winch can lift or pull. This is due to the "torque arm" effect. By using a smaller diameter drum, a winch is capable of pulling much greater loads using a lower horsepower motor and less costly gearbox. While this design philosophy provides a cheaper winch, hidden costs such as reduced safety factor, increased maintenance, greater liability, and reduced winch life span can begin to add up. Consequently, some manufacturers will modify their winch to meet B30.7 only upon request and at an additional charge. The illustrations to the right demonstrate the effects of high loads being pulled around a small diameter drum. Such damage shortens the life span of a wire rope and may lead to more frequent replacement of this critical component. *Photos courtesy of Wire Rope Users Manual, Third Edition, Second Printing.*



Q: Will the Fulcrum be available in Air and Hydraulic versions?

A: Air ("A" series) and hydraulic ("H" series) are available upon request. Please contact Client Services with your requirements so they may provide a quotation.

Q: What about design modifications to meet special applications?

A: "All you have to do is ask." 30-40% of our business is providing customized solutions for specific applications. We recognize that not all jobs are created equal and that the most cost-effective solutions may not be in an off-the-shelf item. We've designed and manufactured winches for applications as simple as moving bags of lettuce, to as intricate as installing critical payloads on space vehicles.

Line Speed Specifications (US)

Frame	Pulling model 15:1 D/d ratio	Lifting model 18:1 D/d ratio	Std drum		Line pull, layer (lbs)			Std line speed, layer (fpm)			Wire rope size in.	Drum capacity, layer (ft)			
			length in.	hp	1st	mid	full	1st	mid	full		1st	mid	<2 layers ⁽¹⁾	full ⁽²⁾
3	EP5300-17-18	EL5300-17-18	18	3	5300	4000	3200	17	23	28	1/2	84	387	768	1066
3	EP6700-20-17		18	5	6700	4900	4200	20	28	32	9/16	75	351	578	840
3		EL6000-23-18	18	5	6000	4900	4200	23	28	32	9/16	84	277	506	768
4	EP8200-23-24	EP8200-23-24	24	7.5	8200	6200	5000	23	30	37	5/8	111	515	1024	1421
4	EP11700-13-27		24	5	11700	8500	7200	13	17	21	3/4	93	443	733	1070
4		EL9200-23-24	24	7.5	9200	7700	7100	23	28	30	3/4	120	394	548	892
5	EP15900-19-24		24	10	15900	11900	10200	19	26	30	7/8	103	481	790	1145
5		EL14100-22-24	24	10	14100	11700	10100	22	26	30	7/8	117	385	699	1059
5	EP20600-19-24		24	15	20600	16400	13600	19	24	29	1	90	305	566	872
5		EL16400-20-24	24	15	16400	14900	13600	20	22	24	1	114	240	378	686
6	EP26000-17-24		24	20	26000	18900	16000	17	23	28	1-1/8	91	433	718	1048
6		EL21300-21-24	24	20	21300	17700	16300	21	25	27	1-1/8	112	371	518	1026
7	EP31900-20-24		24	20	31900	26000	22000	20	24	28	1-1/4	101	338	619	1127
7		EL27000-22-24	24	20	27000	22700	21000	22	28	30	1-1/4	120	395	549	892
7	EP38400-20-24		24	25	38400	30800	25700	20	25	30	1-3/8	92	310	573	881
7		EL32600-19-24	24	20	32600	29500	27000	19	21	22	1-3/8	109	230	362	659
8	EP45600-18-30		30	30	45600	37200	31500	18	22	26	1-1/2	127	423	776	1186
8		EL42400-20-30	30	30	42400	35100	29900	20	24	28	1-1/2	137	453	826	1255

Line Speed Specifications (Metric)

Frame	Pulling model 15:1 D/d ratio	Lifting model 18:1 D/d ratio	Std drum		Line pull, layer (kg)			Std line speed, layer (mpm)			Wire rope size (mm)	Drum capacity, layer (m)			
			length mm	hp	1st	mid	full	1st	mid	full		1st	mid	<2 layers ⁽¹⁾	full ⁽²⁾
3	EP5300-17-18	EL5300-17-18	457	3	2409	1818	1455	5	7	9	13	26	118	234	325
3	EP6700-20-17		457	5	3045	2227	1909	6	9	10	14	23	107	176	256
3		EL6000-23-18	457	5	2727	2227	1909	7	9	10	14	26	84	154	234
4	EP8200-23-24	EP8200-23-24	610	7.5	3727	2818	2273	7	9	11	16	34	157	312	433
4	EP11700-13-27		610	5	5318	3864	3273	4	5	6	20	28	135	223	326
4		EL9200-23-24	610	7.5	4182	3500	3227	7	9	9	20	37	120	167	272
5	EP15900-19-24		610	10	7227	5409	4636	6	8	9	22	31	147	241	349
5		EL14100-22-24	610	10	6409	5318	4591	7	8	9	22	36	117	213	323
5	EP20600-19-24		610	15	9364	7455	6182	6	7	9	26	27	93	173	266
5		EL16400-20-24	610	15	7455	6773	6182	6	7	7	26	35	73	115	209
6	EP26000-17-24		610	20	11818	8591	7273	5	7	9	28	28	132	219	320
6		EL21300-21-24	610	20	9682	8045	7409	6	8	8	28	34	113	158	313
7	EP31900-20-24		610	20	14500	11818	10000	6	7	9	32	31	103	189	344
7		EL27000-22-24	610	20	12273	10318	9545	7	9	9	32	37	120	167	272
7	EP38400-20-24		610	25	17455	14000	11682	6	8	9	36	28	95	175	269
7		EL32600-19-24	610	20	14818	13409	12273	6	6	7	36	33	70	110	201
8	EP45600-18-30		762	30	20727	16909	14318	5	7	8	40	39	129	237	362
8		EL42400-20-30	762	30	19273	15955	13591	6	7	9	40	42	138	252	383

(1) <2 layers = full drum less 2 layers for working

(2) full = full drum for storage

Drum Lengths

Frame	Pulling	Lifting	Available Drum Length in. (mm)						
			18 (457)	24 (610)	30 (762)	36 (914)	42 (1067)	48 (1219)	54 (1372)
3	EP5300-18	EL5300-18	Std	–	Opt	–	Opt	–	–
3	EP6700-23	EL6700-25	Std	–	Opt	–	Opt	–	–
4	EP8200-19	EL8200-19	–	Std	–	Opt	–	Opt	–
4	EP11700-14	EL9200-18	–	Std	–	Opt	–	Opt	–
5	EP15900-21	EL14100-23	–	Std	–	Opt	–	Opt	–
5	EP20600-21	EL16400-26	–	Std	–	Opt	–	Opt	–
6	EP26000-18	EL21300-23	–	Std	–	Opt	–	Opt	–
7	EP31900-21	EL27000-24	–	Std	–	Opt	–	Opt	–
7	EP38400-25	EL32600-25	–	Std	–	Opt	–	Opt	–
8	EP45600-21	EL42400-23	–	–	Std	–	Opt	–	Opt

Note: Dimensions are for standard base models only and subject to change. For optional drum lengths and gearbox combinations please contact the factory for dimensional drawings.

Dimensions (Standard Winch Model)

Pulling

Frame	Model	"A" Std Drum		B		C		E		N		P		R		S		T			
		in.	mm	in.	mm	in.	mm	in.	mm	in.	mm	in.	mm	in.	mm	in.	mm	in.	mm		
3	EP5300-17-	18	457	25.89	658	7.50	190	14.12	359	28.25	718	8.62	219	4.19	106	7.76	197	23.93	608	9.84	250
3	EP6700-20-	18	457	25.89	658	7.50	190	14.12	359	28.25	718	8.62	219	4.19	106	10.83	275	34.93	887	11.81	300
4	EP8200-23-	24	610	32.35	822	9.75	248	17.88	454	35.75	908	10.75	273	5.86	149	7.76	197	23.93	608	9.84	250
4	EP11700-13-	24	610	32.35	822	9.75	248	17.88	454	35.75	908	10.75	273	5.86	149	7.76	197	23.93	608	9.84	250
5	EP15900-19-	24	610	34.64	879	7.63	193	19.25	488	38.50	977	14.00	356	7.00	178	10.83	275	33.80	858	11.81	300
5	EP20600-19-	24	610	34.64	879	7.63	193	19.25	488	38.50	977	14.00	356	7.00	178	10.83	275	34.93	887	13.78	350
6	EP26000-17-	24	610	36.51	927	6.62	168	20.25	514	40.50	1028	16.00	406	9.00	229	13.03	331	40.72	1034	13.78	350
7	EP31900-20-	24	610	36.65	931	8.12	206	20.82	529	41.65	1058	20.00	508	9.00	229	13.03	331	40.72	1034	13.78	350
7	EP38400-20-	24	610	36.65	931	8.12	206	20.82	529	41.65	1058	20.00	508	9.00	229	13.03	331	43.56	1106	13.78	350
8	EP45600-18-	30	762	42.50	1080	9.50	241	24.75	629	49.50	1257	24.00	610	10.50	267	13.03	331	43.56	1106	13.78	350

Lifting

3	EL5300-17-	18	457	25.89	658	7.50	190	14.12	359	28.25	718	8.62	219	4.19	106	7.76	197	23.93	608	9.84	250
3	EL6000-23-	18	457	25.89	658	7.50	190	14.12	359	28.25	718	9.75	248	3.63	92	10.83	275	34.93	887	11.81	300
4	EP8200-23-	24	610	32.35	822	9.75	248	17.88	454	35.75	908	10.75	273	5.86	149	7.76	197	23.93	608	9.84	250
4	EL9200-23-	24	610	32.35	822	9.75	248	17.88	454	35.75	908	14.00	356	4.00	102	7.76	197	23.93	608	9.84	250
5	EL14100-22-	24	610	34.64	879	7.63	193	19.25	488	38.50	977	16.00	406	6.00	152	10.83	275	33.80	858	11.81	300
5	EL16400-20-	24	610	34.64	879	7.63	193	19.25	488	38.50	977	18.00	457	5.00	127	10.83	275	34.93	887	13.78	350
6	EL21300-21-	24	610	36.51	927	6.62	168	20.25	514	40.50	1028	20.00	508	7.00	178	13.03	331	40.72	1034	13.78	350
7	EL27000-22-	24	610	36.65	931	8.12	206	20.82	529	41.65	1058	24.00	610	7.00	178	13.03	331	40.72	1034	13.78	350
7	EL32600-19-	24	610	36.65	931	8.12	206	20.82	529	41.65	1058	24.00	610	7.00	178	13.03	331	43.56	1106	13.78	350
8	EL42400-20-	30	762	42.50	1080	9.50	241	24.75	629	49.50	1257	26.00	660	9.50	241	13.03	331	43.56	1106	13.78	350

Frame 3

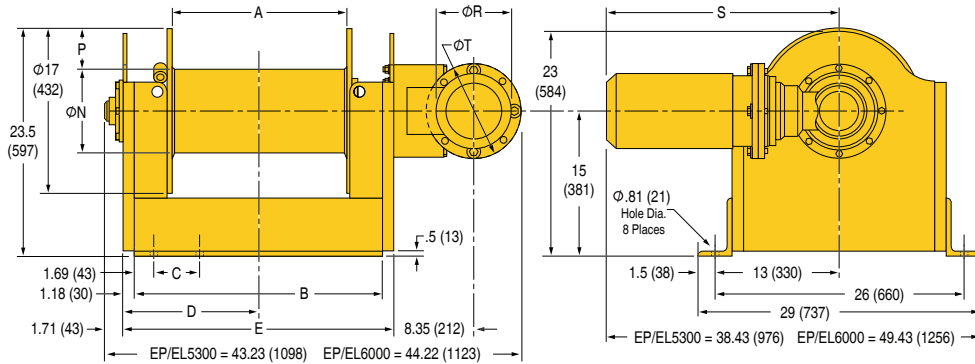

Frame 4

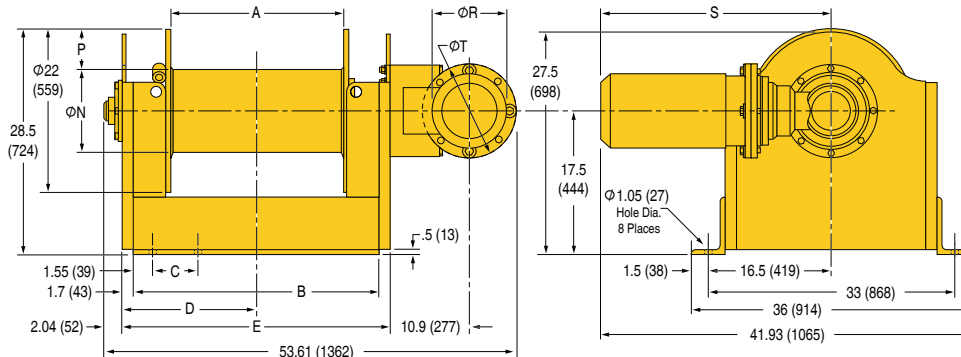

Note: Dimensions are for standard base models only and subject to change. For optional drum lengths and gearbox combinations please contact the factory for dimensional drawings.

Dimensions

Frame 5

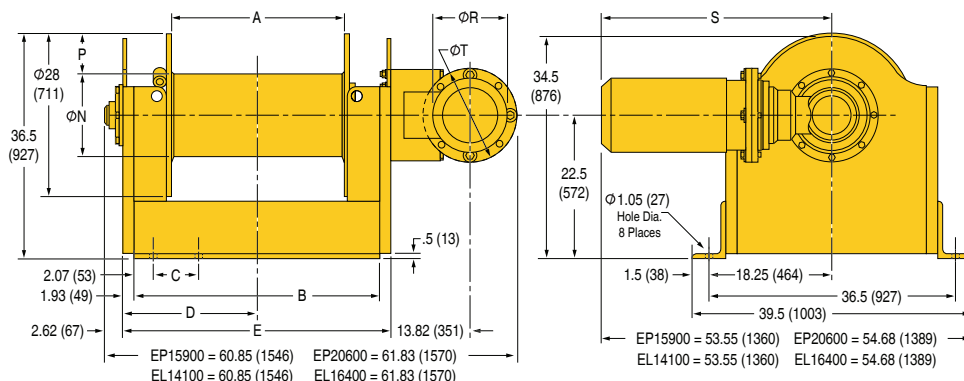

Frame 6

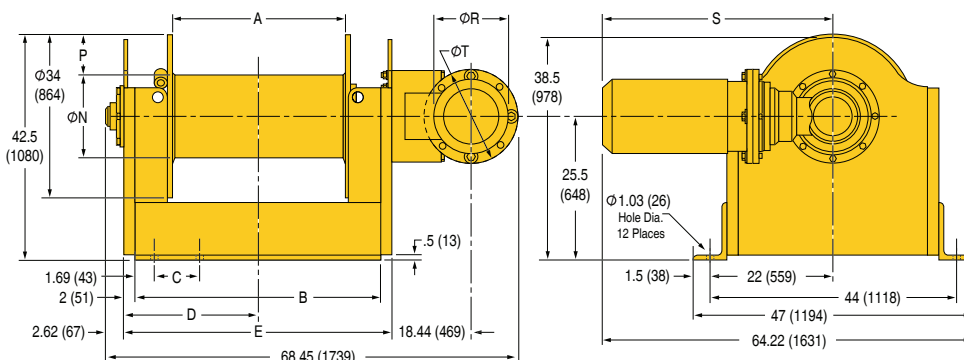

Frame 7

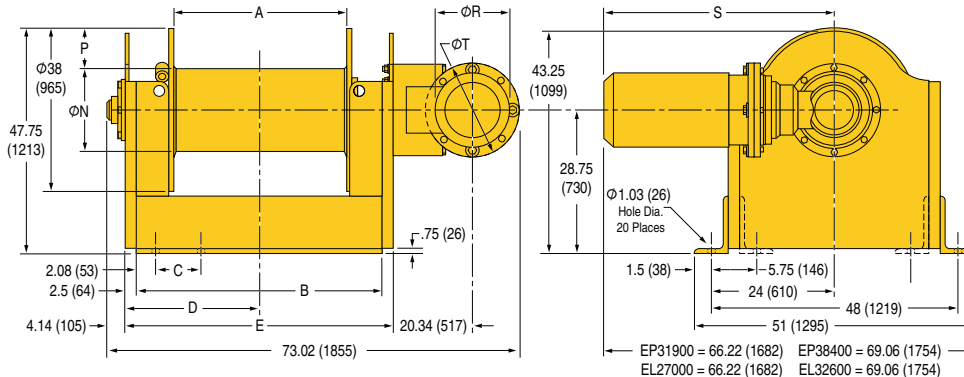

Frame 8

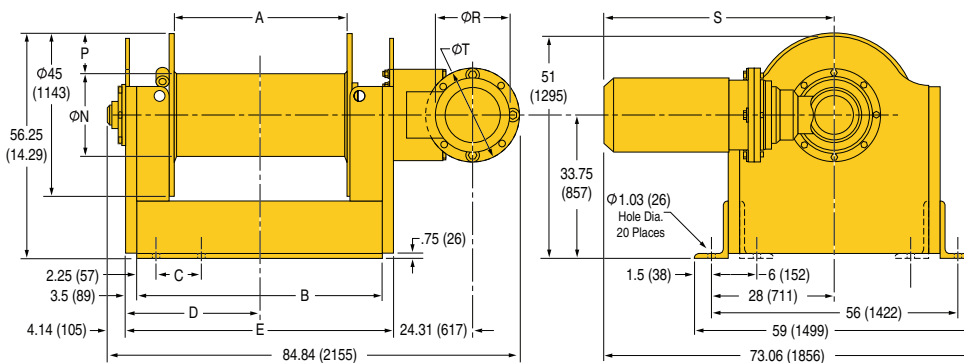

Note: Dimensions are for standard base models only and subject to change. For optional drum lengths and gearbox combinations please contact the factory for dimensional drawings.

Fulcrum versatility provides...

Winch Standard Options

- Drum divider flanges
- Mainline disconnect with “on-off” on pendent
- Free-spooling clutch
- Grooved drums
- Space heater in motor and control boxes
- Hand crank for manual operation in the event of power failure
- Drum locking pin
- Marine duty, IEEE45 motor
- Mirror image versions
- Marine 812-X paint specification
- Press roller on drum
- NEMA 4 upper and lower, rotary limit switches
- Drum guards
- Manual level wind and drum guard combinations
- Dual speed motors
- Electronic overload limiter
- Sandblast/Carbozinc surface preparations



50,000 pound hose positioning winch



38,400 pound railway car moving winch

Other engineered options available upon request

- Horizontal load reversing drums
- Multiple brakes
- Explosion proof motors and control systems
- Programmable logic controls (PLC)
- Variable frequency (speed) drives (VFD) and vector duty motors
- Wireless infrared and radio controls
- Man Riding winches
- European Machinery Directive compliant models
- Hydraulic and air versions
- Custom paint coating systems and colors



21,300 pound maintenance winch with dual brakes and vector duty motor

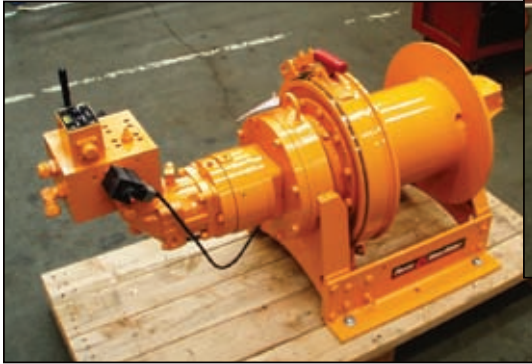

16,400 pound hydraulic pipe handling winch

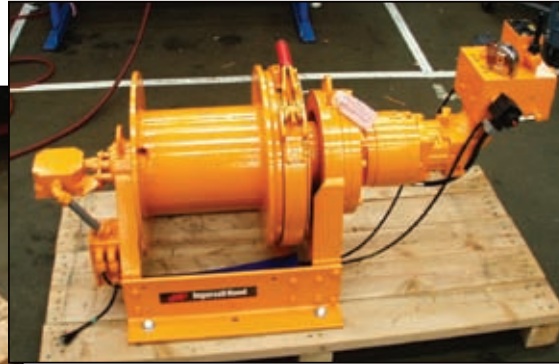

Custom launch vehicle payload handling winch



Man Rider™ winches



Explosion proof motors and controls



Extended drums

IR Winch Check List

Fax: 206-624-6265; Toll Free: 866-273-3278; email: WinchandHoistSolutions@irco.com



This form should accompany all winch inquiries. Use of this check list will help minimize changes after the order has been entered.

Distributor _____ End user _____

Contact name _____ Contact name _____

Fax/phone no. _____ Fax/phone no. _____

Reference no. (order/inquiry/bid) _____ Reference no. (order/inquiry/bid) _____

General description/model or application requirements (please describe in detail the application and provide a sketch or drawing if possible).

_____ Quantity _____

Power source:

Manual _____

Air (pressure, flow) _____

Electric (cycles, phase, voltage) _____

Hydraulic (pressure, flow) _____

Lifting or pulling application _____ How far/how high _____

Selected winch capacity _____ Winch speed? _____ fpm

Speed at mid-drum, top or first wrap layer? _____ fpm

Drum storage _____ Rope diameter _____ in./min

Duty cycle (if known) _____ Environment _____

Time required to complete lift or pull (speed) _____ fpm

Control type (local, remote, electrical voltage. Include maximum distance.) _____

Special standards or documents required? _____ Name/no. _____

Special paint/color/coating? _____ Details _____

Special manufacturing requirements? _____ QA/QC _____

Options:

Brakes Manual _____ Auto _____ Band _____

Disc _____ Special _____

Drum Standard _____ Other length _____ Flange _____

Grooving _____ Divider flange _____

Drum guard _____ (fixed/movable)

Air line equipment (FRL's, muffler, tension manifold) _____

Other options _____

Attach additional sheets if required and sketches if possible.

Winch and Hoist Solutions Limited Warranty

Ingersoll-Rand (IR) warrants to the original user its Winch and Hoist Solutions Products to be free of defects in material and workmanship for a period of one year (**two years for all Fulcrum™ electric winches**) from the date of purchase. IR will repair without cost any Product found to be defective, including parts and labor charges; or at its option, will replace such Products or refund the purchase price less a reasonable allowance for depreciation in exchange for the Product. Repairs or replacements are warranted for the remainder of the original warranty period. If any Product proves defective within its original one year warranty period, it should be returned to any Authorized Hoist and Winch Service Distributor, transportation prepaid, with proof of purchase or warranty card.

This warranty does not apply to Products which IR has determined to have been misused or abused, improperly maintained by the user, or where the malfunction or defect can be attributed to the use of non-genuine IR parts. IR makes no other warranty, and all implied warranties including any warranty of merchantability or fitness for a particular purpose are limited to the duration of the expressed warranty period as set forth above. IR's maximum liability is limited to the purchase price of the Product and in no event shall IR be liable for any consequential, indirect, incidental, or special damages of any nature arising from the sale or use of the Product, whether based on contract, tort, or otherwise.

Note: Some states do not allow limitations on incidental or consequential damages or how long an implied warranty lasts so that the above limitations may not apply to you. This warranty gives you specific legal rights and you may also have other rights which may vary from state to state.

Fulcrum Two Year Limited Warranty

The IR Winch and Hoist Solutions line of powered winches and hoists proudly incorporates over 80 years of combined engineering and manufacturing expertise to build rugged and quality equipment for the most demanding applications in the world. Backed by decades of experience and offices world-wide, IR's warranty is as solid as its heritage; Ingersoll-Rand guarantees its Winch and Hoist Solutions Products to be free of defects in material and workmanship for a period of **two years** on all Fulcrum electric winches or we'll repair (or replace it) for free.

Warranty Registration

Complete this form and drop it in the mail or FAX it to: Ingersoll-Rand, Inc., 1-206-624-6265

Model Number	Serial Number	Purchase Date	
Your Name	Title	Phone Number	
Company Name	E-mail	Fax Number	
Address	State	Zip Code	
City	State	Zip Code	

Distributor Name Where Purchased: _____ Distributor Address: _____

Type of Business:
 Construction
 Petro-Chemical
 Oil Drilling
 Manufacturing
 Mining
 Shipbuilding
 Other: _____

What influenced your decision to buy:
 Price
 Quality
 Features
 Reliability
 Availability
 Support
 Other: _____

Product used for:
 Lifting
 Pulling

Please describe application: _____



MH-D55319/010103

Office and distributors in principal cities throughout the world. Contact the nearest Ingersoll-Rand office for the name and address of the distributor in your country or write to: Ingersoll-Rand, 2724 Sixth Avenue South, Seattle, WA 98134 USA

United States Regional Sales Offices

For Order Entry and Order Status:

Ingersoll-Rand Distribution Center

510 Hester Drive, P.O. Box 618, White House, TN 37188

Phone: (615) 672-0321 Fax: (615) 672-0801

For Technical Support:

Ingersoll-Rand Winch and Hoist Solutions

2724 Sixth Avenue South, Seattle, WA 98134

Phone: (206) 624-0466 Fax: (206) 624-6265

Toll Free: (866) 273-3278

Email: WinchandHoistSolutions@irco.com

Website: www.WinchandHoistSolutions.com

www.fulcrumwinch.com

International

National Sales Office Regional Warehouse

Toronto, Ontario

51 Worcester Road, Rexdale, Ontario M9W 4K2

Phone: (416) 213-4500 Fax: (416) 213-4510

Order Desk: (377) 924-7435 Fax: (416) 213-4506

Latin America Operations

Ingersoll-Rand Production Equipment Group

730 N.W. 107 Avenue, Suite 300, Miami, Florida 33172-3107

Phone: (305) 559-0500 Fax: (305) 222-0864

Europe, Middle East and Africa

Ingersoll-Rand Material Handling – Douai Operations

111, avenue Roger Salengro, 59450 SIN LE NOBLE, France

Phone: (33) 3-27-93-08-08 Fax: (33) 3-27-93-08-00

Ingersoll-Rand SEA Pte. Ltd.

42 Benoi Road, Jurong, Singapore 629903

Phone: (65) 6861-1555 Fax: (65) 6862-1373

Russia Ingersoll-Rand Co.

Presnensky Val, 19, Moscow, Russia 123557

Phone: (7) 095-933-03-24 Fax: (7) 095-737-01-48

Phone: (7) 095-933-03-21



Australia Ingersoll-Rand Ltd.

Landmark Corporate Centre

Level 2, 454-472 Nepean Highway, Frankston, Vic. Australia 3199

Phone: (61) 3-8781-1600 Fax: (61) 3-8781-1611

WARNING: This equipment is not designed for transporting people or lifting loads over people. It is the user's responsibility to determine the suitability of this product for any particular use and to check compliance with applicable regulations. Before installation, see maintenance and operations manual for additional warnings and precautions.

Call 1-800-IR HOIST (474-6478) for the distributor nearest you.

Visit our website at: www.WinchandHoistSolutions.com

© 2005 Ingersoll-Rand Company Form No. MHD55327/082305 Printed in U.S.A./2K



FM 53539



High Performance Ergonomics™